

LX1632 180CFX - Pinion 9T MOD 0.4 - 2mm Shaft

Step 1

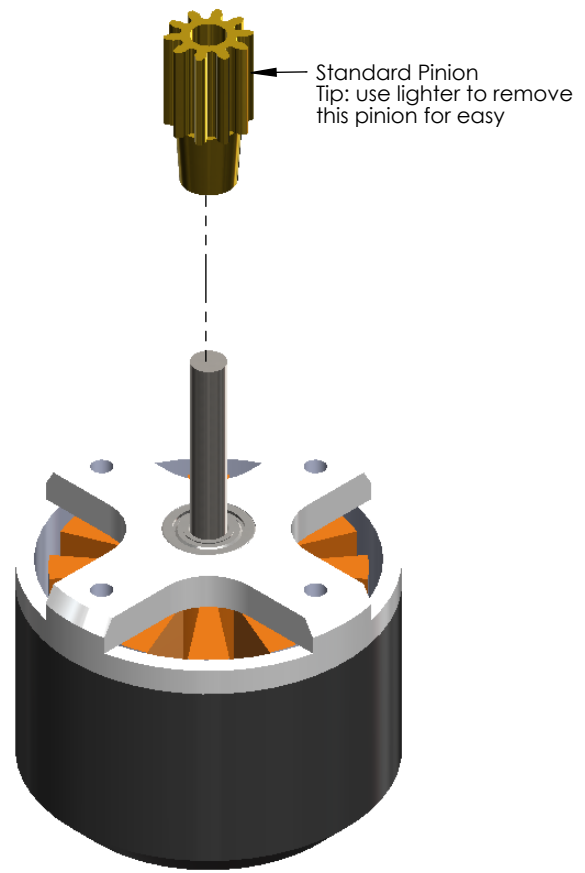

Step 2

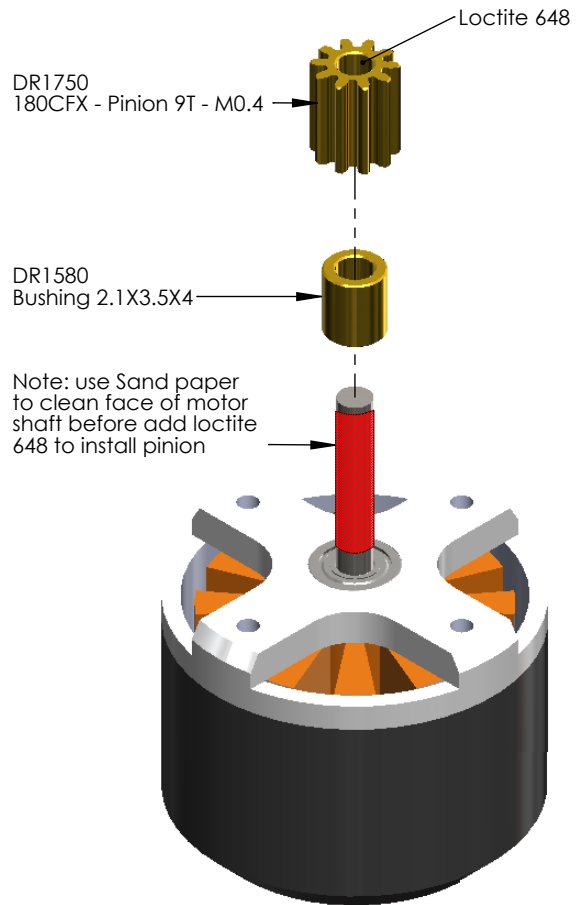

Assembly finish

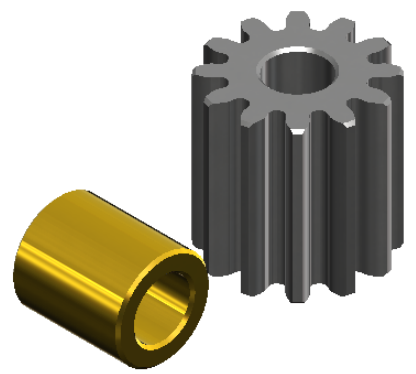

Assembly note