

LX0632 300 X - ULTRA TAIL PITCH SLIDER - SILVER
LX0723 300 X - ULTRA TAIL PITCH SLIDER - RED

STEP 1

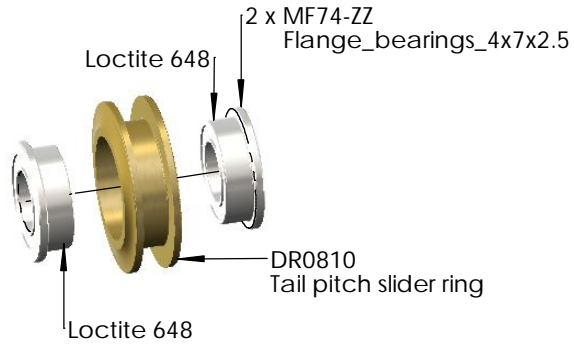

STEP 2

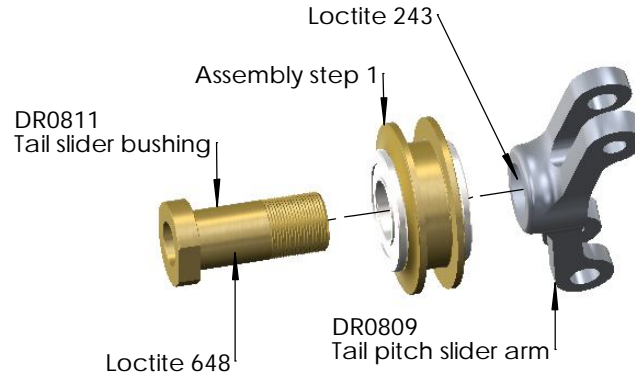

STEP 3
2 pc

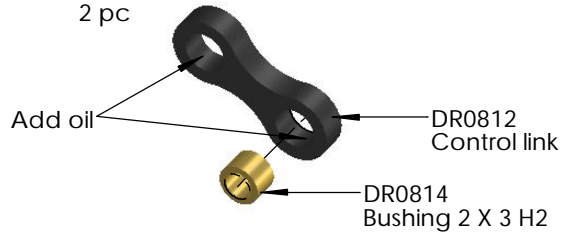

STEP 4

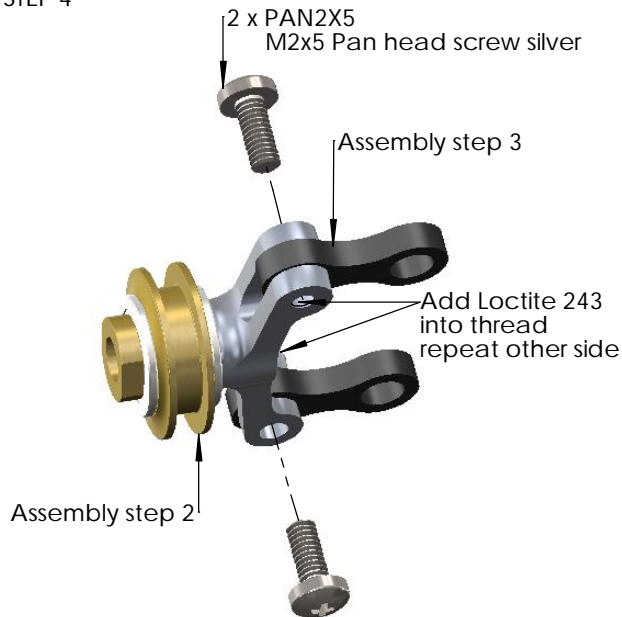

STEP 5

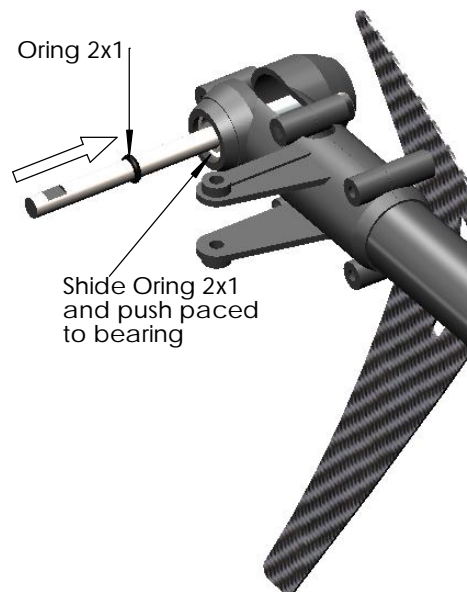

IMPORTANT INSTALL NOTE

-When tail rotor hub is install adjust position and lock set screw M3x3 with outer tail shaft surface and tail hub surface tangent(see shown picture)

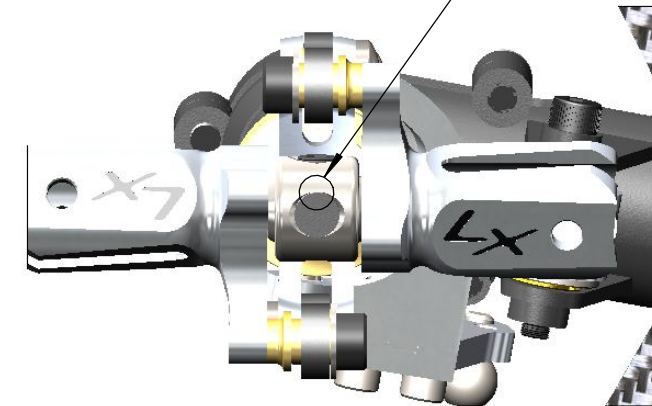

STEP 6 - FINAL ASSEMBLY INTO HELI

Install tail grip
 - add CA into plastic tail grip
 - add loctite 243 into alu tail grip
 repeat both tail grip

